

HARDWARE REFERENCE

IMM-NRF51822 Micro-module



Copyright © 2014 I-SYST, all rights reserved.

This document may not be reproduced in any form without, express written consent from I-SYST.

Limited Warranty

The IMM-NRF51822 Micromodule is warranted against defects in materials and workmanship for a period of 30 days from the date of purchase from I-SYST or from an authorized dealer.

Disclaimer

I-SYST reserves the right to change this product without prior notice. Information furnished by I-SYST is believed to be accurate and reliable. However, no responsibility is assumed by I-SYST for its use; nor for any infringement of patents nor other rights of third parties which may result from its use. No license is granted by implication or otherwise under the patent rights of I-SYST.

Trademark

ARM® Cortex™ are registered trade mark of ARM
Bluetooth® is a registered trade mark of Bluetooth SIG

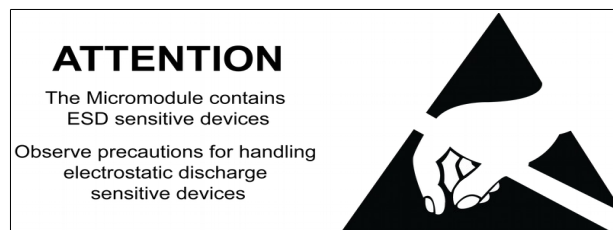

Table of Contents

Introduction.....	1
<i>Features:.....</i>	1
Module Layout.....	2
<i>I/O Pads layout.....</i>	2
<i>SMD Foot Print.....</i>	3
<i>Through Hole Foot Print.....</i>	3
Quick Start.....	4
<i>Requirements.....</i>	4
<i>Optional 32 KHz crystal wiring.....</i>	4
<i>Flashing firmware.....</i>	4
<i>Breakout board.....</i>	5
<i>Jtag wiring.....</i>	5
<i>Nordic Software.....</i>	6
<i>Eclipse IDE.....</i>	6

Introduction

The nRF51822 is an ultra low power System on Chip (SoC) from Nordic Semiconductor. It integrates the nRF51 series 2.4GHz transceiver, a 32 bits ARM® Cortex™-M0 CPU, Flash memory, analog and digital I/O. The nRF51822 supports both Bluetooth Low Energy and proprietary protocols.

The IMM-NRF51822 is a 23 x 17 mm micro-module with embedded PCB antenna. It allows developers to take full advantage of the nRF51822 by making all its I/O available via 35 SMD/Through hole 1.27mm pitch pads. The module can be mounted with header pins in order to re-use during development and prototyping phase and SMD it for production to be the most cost effective.

Features:

- 32 bits ARM® Cortex™-M0 @ 16MHz.
- 2.4GHz multi-protocol transceiver
- 16KB SRAM.
- 256KB Flash
- 31 configurable I/O pins
- One 32 and two 16 bit timers with counter mode
- 16 channel CPU independent Programmable Peripheral Interconnect (PPI)
- Encryption -128 bit AES ECB/CCM/AAR co-processor
- RNG
- RTC
- Temperature sensor
- Up to 4 PWM
- Digital interfaces SPI Master/Slave, 2-wire Master (I2C compatible), UART (CTS/RTS)
- Quadrature decoder
- 8/9/10 bit ADC - 8 configurable channels
- Low power comparator
- Operating voltage : 1.8V to 3.6V
- Dimension : 23 x 17 mm

Module Layout

I/O Pads layout

Bellow is the direct relationship of the module pads and the nRF51822 I/O pins. Shared peripherals pins are also indicated.

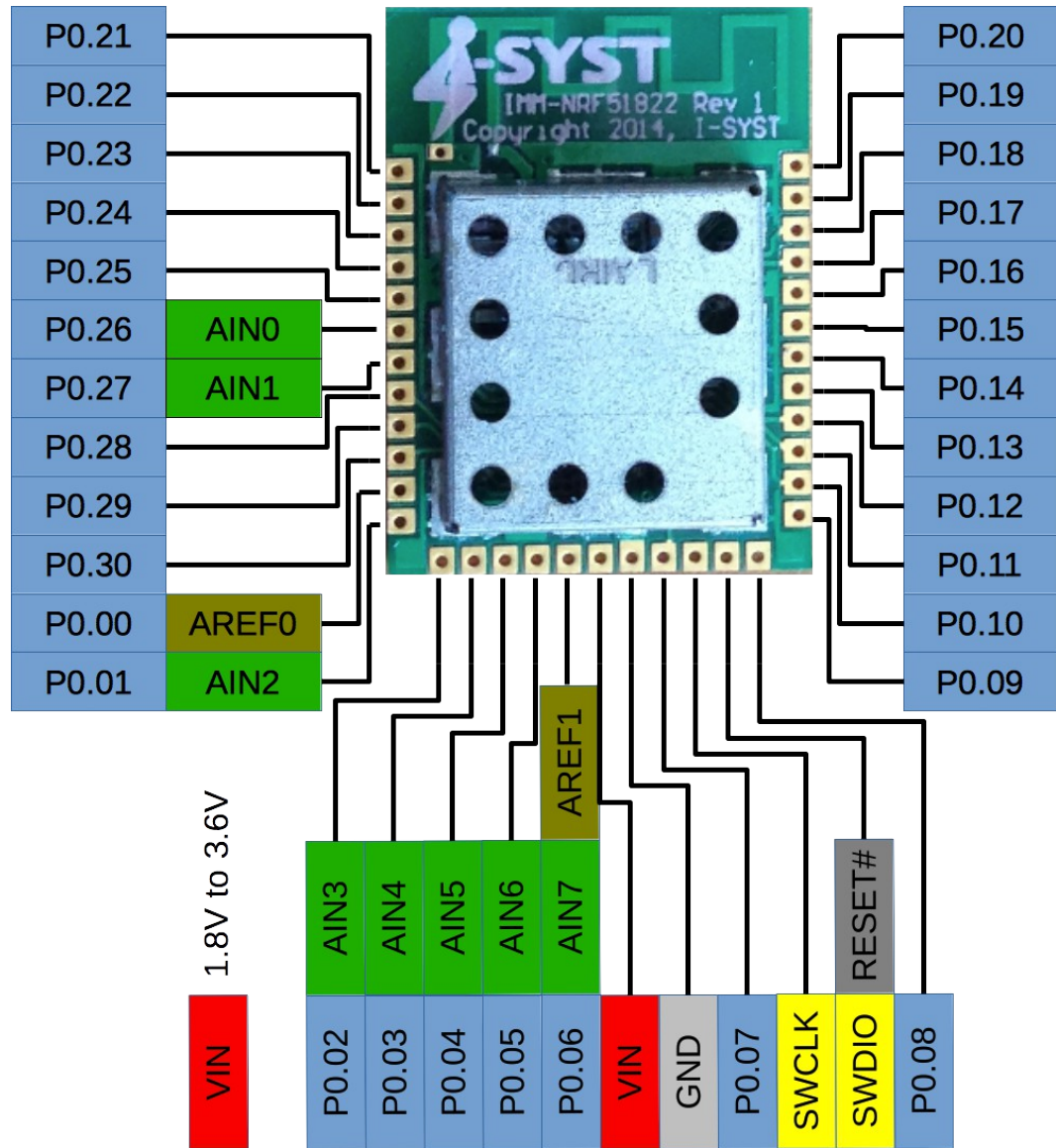
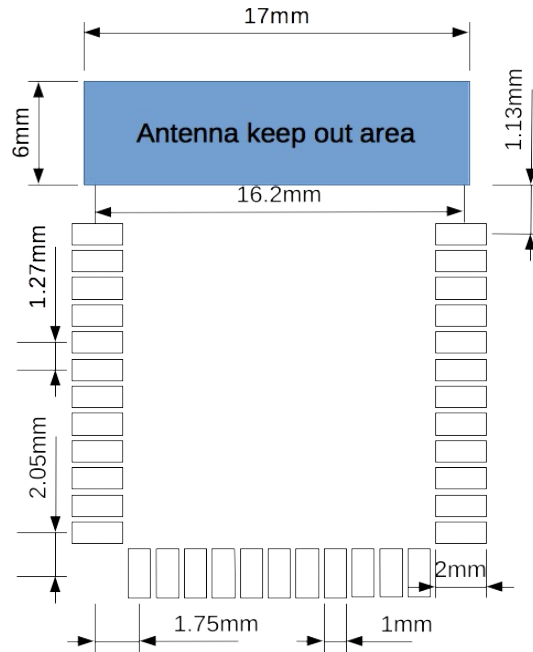

Fig. 1: I/O mapping

SMD Foot Print

Note : Do not route any traces or planes under the indicated antenna area.



Through Hole Foot Print

Note : Do not route any traces or planes under the indicated antenna area.

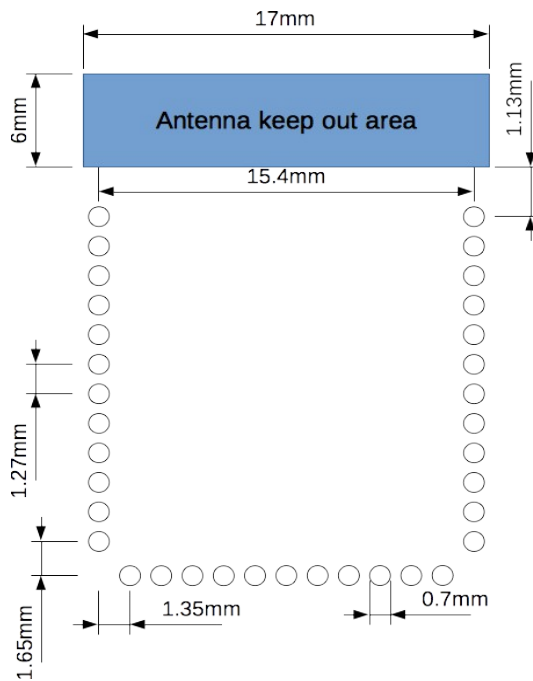

Quick Start

Requirements

The follows are required for software development

- Debug Jtag : Segger J-Link, IDAP-Link, or any ARM compatible Jtag.
- Nordic SDK & Softdevice BLE stack (require product key)
- C/C++ embedded software development environment : Eclipse, Keil, CrossWorks, ...

Optional 32 KHz crystal wiring

The module does not have the 32KHz crystal installed. It is optional. If your application requires it. It can be wire to the module as shown bellow. The capacitor value depends on the crystal chosen. It can be approximate as $2 * C1 - 4$, where C1 is the load capacitance of the crystal.

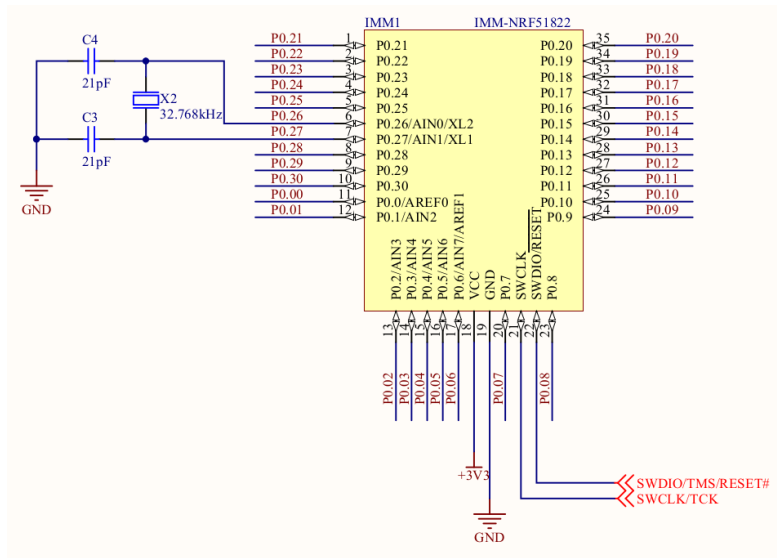

Fig. 2: IMM-NRF51822 - 32KHz Crystal wiring

Flashing firmware

The Nordic Softdevice is required to use BLE application. There are many methodes to flash it in the module. The official methode form Nordic is to use nRFG0 with J-Link. This program is available only on Windows operating system. The other methode is to use IDAPnRFProg for OSX & Windows. More details available on blog page <http://embeddedsoftdev.blogspot.ca/p/ehal-nrf51.html>. The IDAPnRFProg can program Softdevice, DFU and Firmware app without requiring mergehex. It can parallel program multiple nRF51 boards at once when multiple IDAP-Link are connected to PC.

Breakout board

The module can also be mounted on the optional breakout board, the IBK-BLUEIO. This breakout board has all I/O pins routed out to standard DIP32, 2.54mm pitch header pin, with onboard LED indicator and coin battery holder. Ready to be mounted on a breadboard. The SWD pins are also routed out for debug probe. Connect it to the IDAP-Link for OpenOCD debugging or turn the IMM-NRF51822 into mBed compatible.

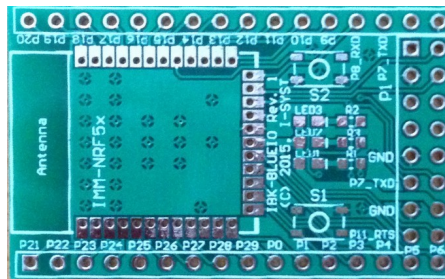

Fig. 3: IBK-BLUEIO - Breakout board for the IMM-NRF51822, IMM-NRF51422, IMM-NRF52832 Modules

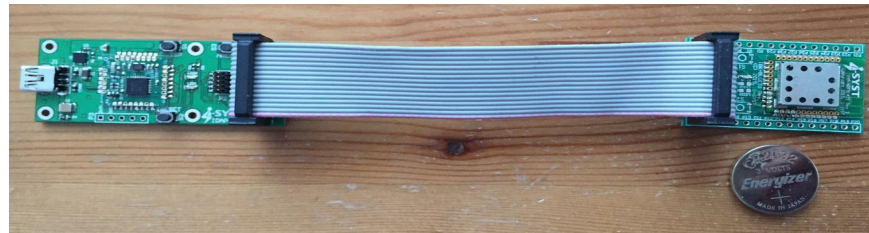

Fig. 4: Connecting IDAP-Link to the breakout board

Jtag wiring

The IMM-NRF51822 micro-module has exposed the SWD (Serial Wire Debug) pins SWDIO & SWCLK, see I/O layout section. The module can be directly connected to a Jtag tool for development by wiring the 2 SWD pins to the appropriate pins on the Jtag connector. The VIN must be wire to the VCC pin on the Jtag. GND pad is also require to be connected to GND on Jtag.

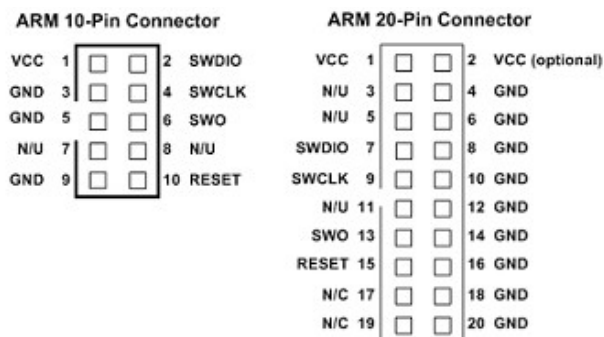

Fig. 5: ARM JTAGE Connector

The module can be powered from 1.8V to 3.6V on VIN. It could be coin battery or DC supply source.

Nordic Software

The module comes with a product key for access to download Nordic SDK and software tools. The key can be found on the included I/O layout and foot print card. To download the SDK, go to <http://www.nordicsemi.com> website. Register a user account then add the product key into your profile. Community support at <https://devzone.nordicsemi.com>.

Eclipse IDE

Eclipse with GCC is the most cost effective software development environment. It is 100% free. The drawback is that it requires a bit of gymnastics to setup. Fortunately many Blog posts are available on the Internet showing step by step. Follow this blog to setup the Eclipse IDE & GCC compiler: <http://embeddedsoftdev.blogspot.ca/p/eclipse.html>.

There are samples code in the Nordic SDK itself. Other Eclipse based example code are available from this Blog page <http://embeddedsoftdev.blogspot.ca/p/ehal-nrf51.html>